

ACHTUNG: Tierspielzeug - nicht unzerstörbar! - Benutzung nur unter unmittelbarer Aufsicht von Erwachsenen! Nicht für Kinder geeignet! Gefahr des Verschluckens von Kleinteilen! Gefahr der Strangulation!

ATTENTION: Animal toy - not indestructible! Usage under direct supervision of adults only! Not suitable for children! Danger of swallowing small pieces! Danger of strangulation!

LET OP: Huisdier Speelgoed- niet onverwoestbaar! Gebruik alléén onder strikt toezicht van een volwassene! - Niet geschikt voor kinderen! - Gevaar voor inslikken van kleine onderdelen! Risico tot wurging!

ATTENTION: Jouet pour animal de compagnie - n'est pas indestructible! A utiliser sous la surveillance d'un adulte! - Ne convient pas aux enfants! Risque d'ingestion de petites pièces! Risque de strangulation!

ATTENZIONE: Giocattolo per animali - non è indistruttibile! Utilizzare sotto la diretta supervisione degli adulti! - Non adatto per bambini! Pericolo di ingestione di piccole parti! Pericolo di soffocamento!

ATENCIÓN: Juguete para animales - no es indestructible! Uso bajo supervisión directa de adultos! No es apto para niños! Peligro de ingestión de piezas pequeñas! - Peligro de asfixia!

PA07-01-034-06

Ref.No.
431-445860



EUROPET BERNINA INTERNATIONAL B.V.

P.O. Box 6 - 5420 AA Gemert-Bakel
The Netherlands

info@ebi.eu - www.ebi.eu

Part of



Pyrite

Bauanleitung - Assembly instruction - Montage-instructies - Instructions de montage -
istruzioni di montaggio - Instrucción de montaje

1

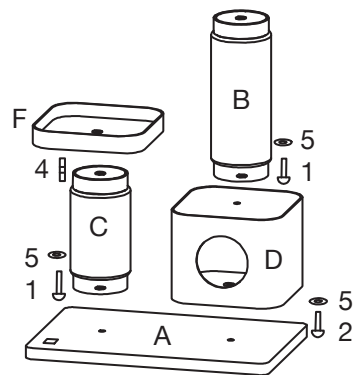

2

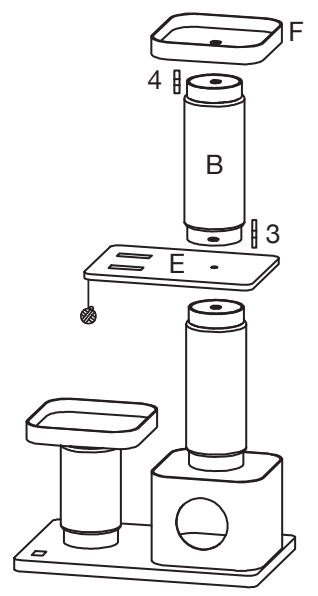

3

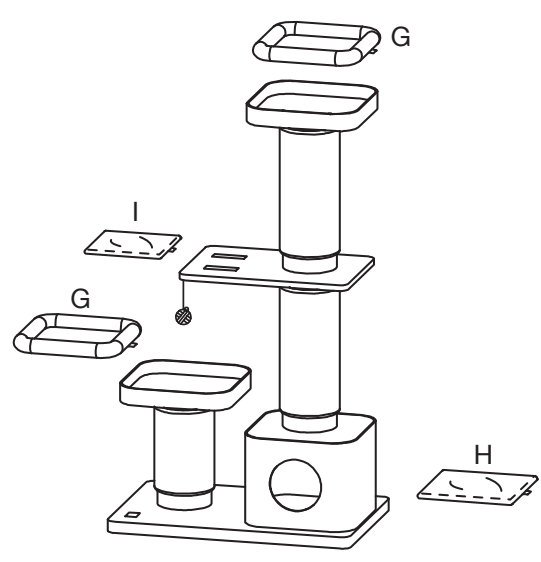

4

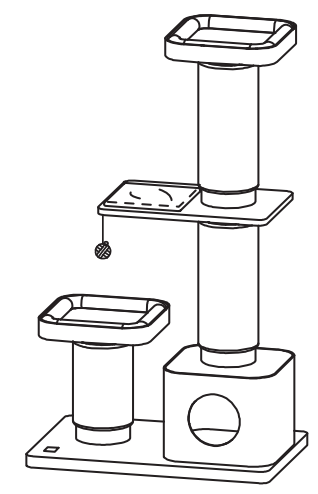

Teile / Delen / Pièces / Parts /
Parti / Piezas

- 1X 86 x 56 x 4 cm (A)
- 2X Ø 20 x 55 cm (B)
- 1X Ø 20 x 40 cm (C)
- 1X 40 x 40 x 30 cm (D)

- 1X 60 x 40 x 2 cm (E)
- 2X 40 x 40 x 7 cm (F)
- 2X 38 x 38 x 4,5 cm (G)
- 1X 38 x 38 cm (H)
- 1X 30 x 36 cm (I)

- 2X Ø 10 x 60 mm (1)
- 1X Ø 10 x 40 mm (2)
- 1X Ø 10 x 90 mm (3)
- 2X Ø 10 x 44 mm (4)
- 3X Ø 40 mm (5)

